

The following page(s) are extracted from multi-page Kuhnke product catalogues or CDRoms and any page number shown is relevant to the original document. The PDF sheets here may have been combined to provide technical information about the specific product(s) you have selected.

Hard copy product catalogues, and CDRoms have been published describing Kuhnke Pneumatics, Solenoids, Relays and Electronics; some divided into different books. A list of current publications is available on this web site or from our sales offices. Some may be available for download, but as substantially larger files.

Contact Details

Kuhnke sales and service in the UK

H. Kuhnke Ltd
Unit 21 Abbey Enterprise Center
Premier Way
Romsey
SO51 9AQ

T: 01794 514445

F: 01794 513514

Email: sales@kuhnke.co.uk

Important Note

The information shown in these documents is for guidance only. No liability is accepted for any errors or omissions. The designer or user is solely responsible for the safe and proper application of the parts, assemblies or equipment described.

Continuous Cycling Timer Circuit Using PT Timers

Continuous cycling is accomplished by the use of 2 timers operating a spring return air piloted valve. Off and on times are dependent on the time range of the timers used. The size of the air piloted valve determines the air volume output.

Operation

System pressure is turned on. Air flows through port 2 of Timer #2 to drive timer #1 and to operate the air pilot valve turning on air to the device being controlled. When timer 1 reaches set time, it sends a signal to port C of timer 2, shutting down the air supply to the air piloted valve and timer 1. This enables timer 2 to begin timing. When timer 2 reaches set time, it operates and the cycle is repeated. Removing the air supply resets the circuit to the start position.

Typical Item Selection

One On Delay PT timer and one Off Delay PT timer with the required time ranges.

Single air piloted, spring return valve, 3/2, cat. no. 76026-71-21 (1/8), 76046-71-21 (1/4), 76066-81-21 (1/2). For operating double acting cylinders use 5/3 valves.

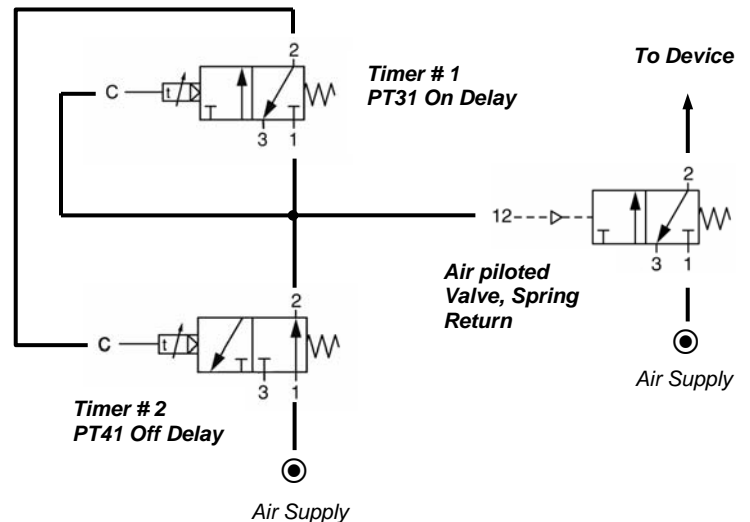

Using a Momentary Start Signal with an Off Delay PT 41 or PT45 Timer

One shot timing can be initiated from a momentary air signal using a PT41 or PT45 off delay timer.

Operation

A momentary pilot pressure applied to the control port from a pushbutton or similar device switches the timer valve and provides an output. Releasing the button starts the timing cycle. When the set time is reached, the valve operates, shutting down the output to the device being controlled.

Typical Item Selection

Any PT41 or PT45 timer.
Pushbutton catalogue number 76022-62-21 (Red) or other valve with a momentary output signal.

