

The following page(s) are extracted from multi-page Kuhnke product catalogues or CDRoms and any page number shown is relevant to the original document. The PDF sheets here may have been combined to provide technical information about the specific product(s) you have selected.

Hard copy product catalogues, and CDRoms have been published describing Kuhnke Pneumatics, Solenoids, Relays and Electronics; some divided into different books. A list of current publications is available on this web site or from our sales offices. Some may be available for download, but as substantially larger files.

Contact Details

Kuhnke sales and service in the UK

H. Kuhnke Ltd
Unit 21 Abbey Enterprise Center
Premier Way
Romsey
SO51 9AQ

T: 01794 514445

F: 01794 513514

Email: sales@kuhnke.co.uk

Important Note

The information shown in these documents is for guidance only. No liability is accepted for any errors or omissions. The designer or user is solely responsible for the safe and proper application of the parts, assemblies or equipment described.

Timing Using a Manual Push-Pull Valve

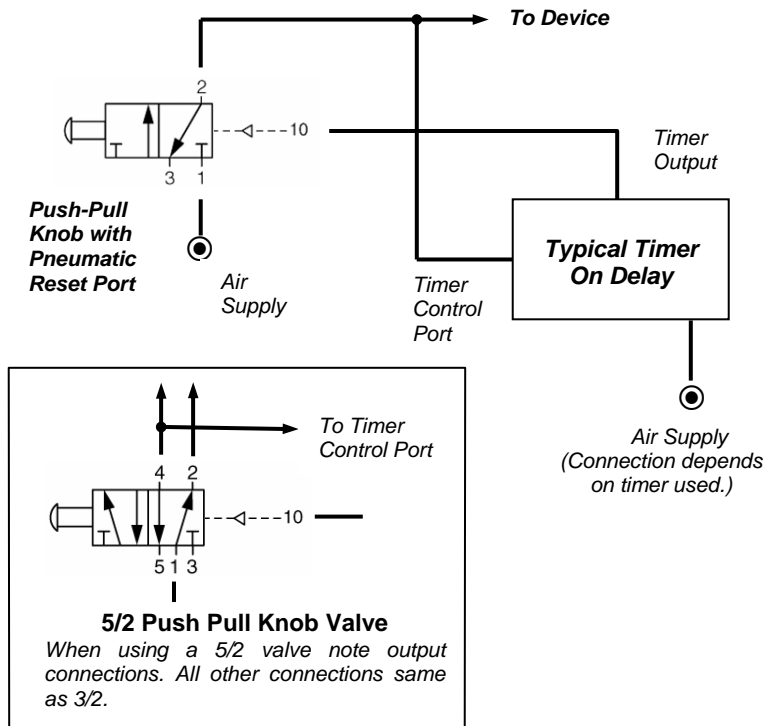

Push-Pull valve can be used to start and stop system manually while providing timing to the circuit. A 5/2 valve can also be used when operating a double acting cylinder, or for alternating outputs.

Operation

Pushing in knob starts air flowing to device and to timer. When the timer reaches set time, it sends a signal to the reset port of the push-pull valve shutting down the air output. To stop the process, pull the knob out, shutting off the air and resetting the timer.

Typical Item Selection

Any on delay timer (Consider length of time required and mounting preference).
 Push-Pull Valve- Cat. nos. 76022-27-22 (3/2, 1/8 ports), 76023-27-42 (5 way, 1/8) or 76043-27-42 (5/2, 1/4).
 Alternative- Lever operated valve, pneumatic reset, contact factory for information.

Converting an On Delay timer output to an Off Delay output

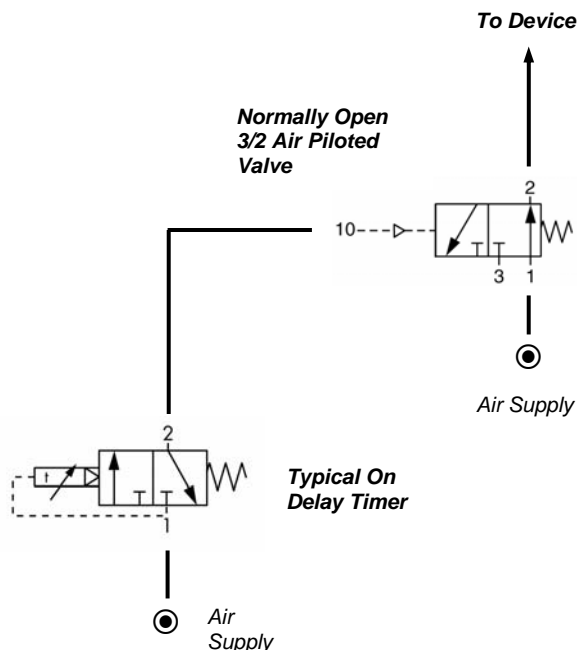

On delay timer signals can be converted to an off delay signal with the use of an interposing normally open 3/2 air piloted valve.

Operation

Air pressure is applied to the timer and to the operating device through the 3/2 piloted valve. When the timer reaches set time, it's output switches the air piloted valve shutting off the air to the device. Removing the air signal from the timer resets the air piloted valve and air flows again to the device.

Typical Item Selection

Any on delay timer (Consider length of time required and mounting preference).
 3/2 air piloted valve (NO) Cat. no. 76036-71-31 (1/8). For larger valves contact factory for information.